

Current Sensing Thick Film Chip Resistors

- Low inductance
- Highly reliable multilayer electrode construction
- Higher component and equipment reliability
- Reduced size of final equipment
- Power management applications
- Switching power supply
- Over current protection in audio application
- Voltage regulation module (VRM)
- DC-DC converter, battery pack, charger, adaptor
- Automotive engine control, Disk driver

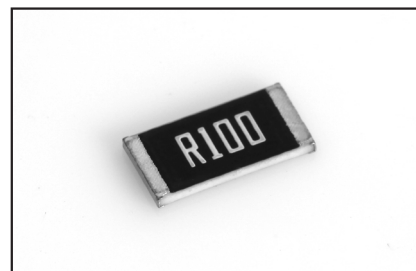

Wire Wound Resistors

Current Sensing Resistors

Precision Resistors

Power Film Resistors

High Voltage Resistors

Bulk Ceramic Resistors

Heaters

GENERAL SPECIFICATIONS

Model	Item	Power Rating at 70 °C	Operating Temperature Range	Resistance Range(mΩ)		TCR(ppm/°C)
				±1%	±5%	
RS-02 (0402)		1/16W	-55 °C ~ +155 °C	50 - 99		±800
				100 - 499		±500
				500 - 976		±200
RS-03 (0603)		1/10W		20 - 47		±1200
				50 - 99		±800
				100 - 499		±500
RS-05 (0805)		1/8W		500 - 976		±200
				10 - 18		±1500
				20 - 47		±1200
RS-06 (1206)		1/4W		50 - 99		±800
				100 - 499		±500
				500 - 976		±200
RS-10 (1210)		1/3W	10 - 18		±1500	
			20 - 47		±800	
RS-0A (2010)		3/4W	50 - 99		±800	
			100 - 499		±200	
RS-12 (2512)		1W	500 - 976		±200	

* Operating Voltage = $\sqrt{P \cdot R}$ / **Overload Voltage = $2.5 \cdot \sqrt{P \cdot R}$

HIGH POWER RATING SPECIFICATIONS

Model	Item	Power Rating at 70 °C	Operating Temperature Range	Resistance Range(mΩ)		TCR(ppm/°C)
				±1%	±5%	
RS-02 (0402)		1/10W	-55 °C ~ +155 °C	50 - 99		±800
				100 - 499		±500
				500 - 976		±200
RS-03 (0603)		1/8W		20 - 47		±1200
				50 - 99		±800
				100 - 499		±500
RS-05 (0805)		1/4W		500 - 976		±200
				10 - 18		±1500
				20 - 47		±1200
RS-06 (1206)		1/3W		50 - 99		±800
				100 - 499		±500
				500 - 976		±200
RS-10 (1210)		1/2W	10 - 18		±1500	
			20 - 47		±800	
RS-0A (2010)		1W	50 - 99		±800	
			100 - 499		±200	
RS-12 (2512)		2W	500 - 976		±200	

* Operating Voltage = $\sqrt{P \cdot R}$

**Overload Voltage = $2.5 \cdot \sqrt{P \cdot R}$

CHARACTERISTICS

Item	Requirement		Test Method
	±1%	±5%	
Temperature Coefficient	As Spec.		-55°C~+125°C, 25°C is the reference temperature
Short Time Overload	±(1.0%+0.05Ω)	±(2.0%+0.05Ω)	RCWV*2.5 or maximum overload voltage for 5 seconds 2 seconds for high power series
Insulation Resistance	≥10GΩ		Maximum overload voltage for 1 minute
Endurance	±(2.0%+0.10Ω)	±(3.0%+0.10Ω)	70±2°C, maximum working voltage for 1000hours with 1.5 hours "ON" and 0.5 hour "OFF"
Damp Heat with Load	±(2.0%+0.10Ω)	±(3.0%+0.10Ω)	40±2°C, 90-95% RH maximum working voltage for 1000 hours with 1.5 hours "ON" and 0.5 hour "OFF"
Dry Heat	±(1.0%+0.05Ω)	±(1.5%+0.05Ω)	At +155°C for 1000hours
Bending Strength	±(1.0%+0.05Ω)	±(1.0%+0.05Ω)	Bending once for 5 seconds 2010, 2512 sizes: 2mm, Other sizes: 3mm
Solderability	95% minimum coverage		245±5°C for 3 seconds
Resistance to Soldering Heat	±(0.5%+0.05Ω)	±(1.0%+0.05Ω)	260±5°C for 10 seconds
Voltage Proof	No breakdown or flashover		1.42 times RCWV(RMS) for 1 minute
Leaching	Individual leaching area ≤ 5% Total leaching area ≤ 10%		260±5°C for 30 seconds
Rapid Change of Temperature	±(0.5%+0.05Ω)	±(1.0%+0.05Ω)	-55°C to +155°C, 5 cycles

* Reference Standards : IEC 60115-1, 60068-2-58; JIS-C 5201-1

* Storage Temperature : 25±3°C; Humidity < 80%RH

DERATING CURVE

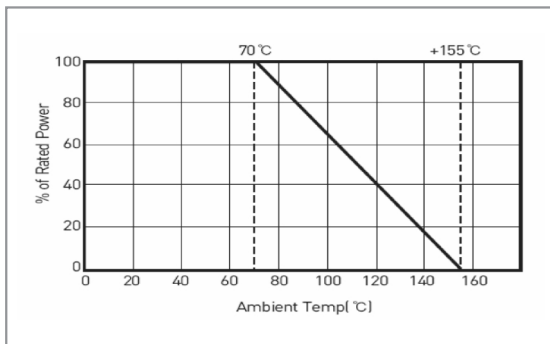

RECOMMENDED LAND PATTERN [mm]

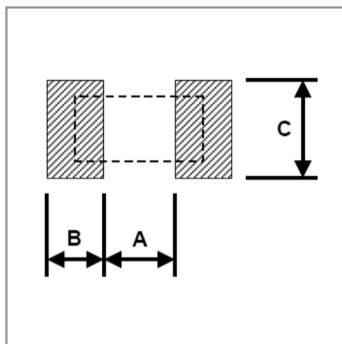

Model	A	B	C
RS-02	0.50	0.45	0.60
RS-03	0.90	0.60	0.90
RS-05	1.20	0.70	1.30
RS-06	2.00	0.90	1.60
RS-10	2.00	0.90	2.80
RS-0A	3.80	0.90	2.80
RS-12	3.80	1.60	3.50

DIMENSIONS [mm]

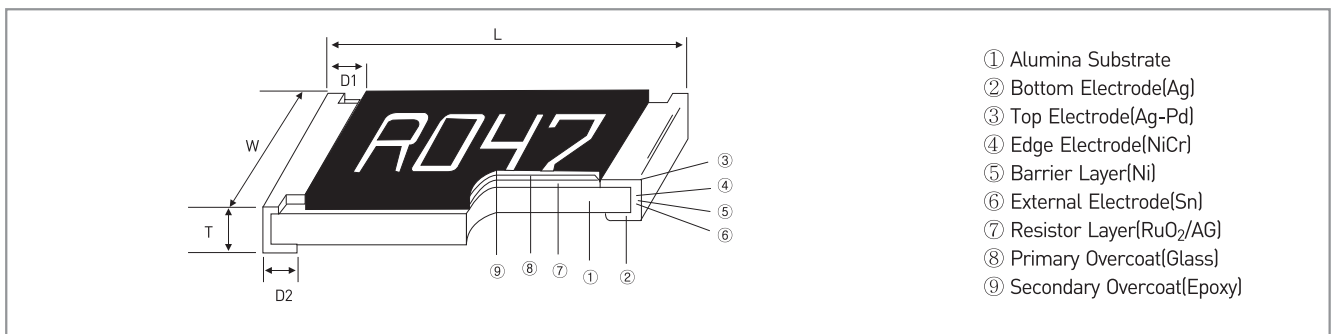

- ① Alumina Substrate
- ② Bottom Electrode(Ag)
- ③ Top Electrode(Ag-Pd)
- ④ Edge Electrode(NiCr)
- ⑤ Barrier Layer(Ni)
- ⑥ External Electrode(Sn)
- ⑦ Resistor Layer(RuO₂/AG)
- ⑧ Primary Overcoat(Glass)
- ⑨ Secondary Overcoat(Epoxy)

Model	Size(Inch)	L	W	T	D1	D2	Weight(g) (1000pcs)
RS-02	0402	1.00±0.05	0.50±0.05	0.35±0.05	0.20±0.10	0.20±0.10	0.620
RS-03	0603	1.60±0.10	0.80±0.10	0.45±0.10	0.30±0.20	0.30±0.20	2.042
RS-05	0805	2.00±0.10	1.25±0.10	0.50±0.10	0.35±0.20	0.40±0.20	4.368
RS-06	1206	3.10±0.10	1.55±0.10	0.55±0.10	0.50±0.25	0.50±0.20	8.947
RS-10	1210	3.10±0.10	2.60±0.15	0.55±0.10	0.50±0.25	0.50±0.20	15.959
RS-0A	2010	5.00±0.10	2.50±0.15	0.55±0.10	0.60±0.25	0.50±0.20	24.241
RS-12	2512	6.35±0.10	3.10±0.15	0.55±0.10	0.60±0.25	0.50±0.20	39.448

PACKAGING

Reel Specifications & Packaging Quantity

Model	Packaging Quantity	Tape Width	Reel Dia.	ΦA	ΦB	ΦC	W	T
RS-02	Paper	10K	7 inch	178.5±1.5	60 ^{+1/-0}	13±0.2	9±0.5	12.5±0.5
		20K						
RS-03 RS-05 RS-06 RS-10	Paper	40K	8mm	10 inch	254±1.0	100±0.5	13±0.2	9.5±0.5
		5K						
		10K						
RS-0A RS-12	Embossed	4K	12mm	7 inch	178.5±1.5	60 ^{+1/-0}	13±0.5	13±0.5
		8K						

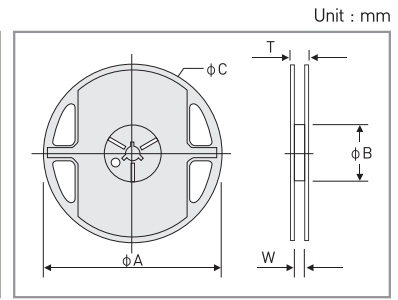

PAPER TAPE SPECIFICATIONS

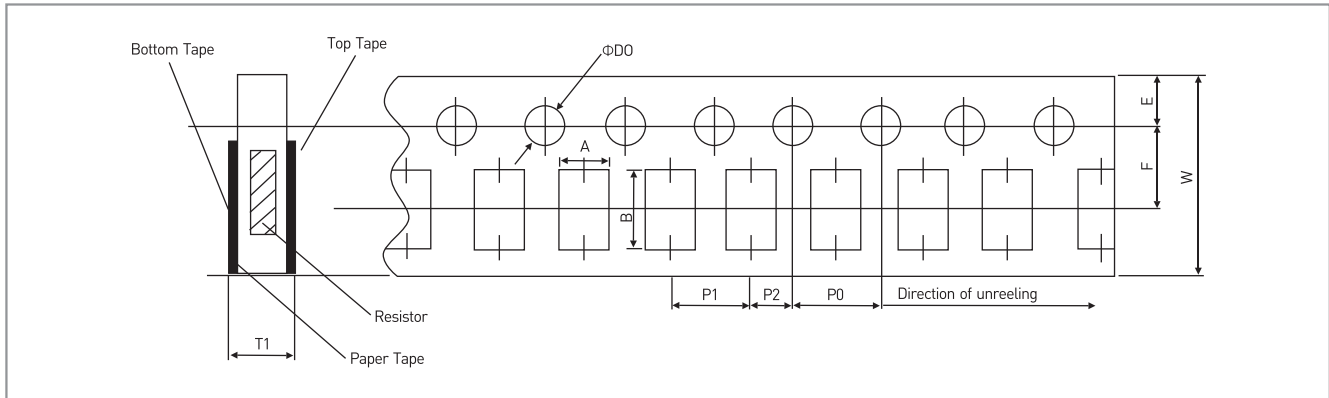

Model	A	B	W	E	F	P ₀	P ₁	P ₂	ΦD ₀	T
RS-02	0.65±0.1	1.15±0.1	8±0.2	1.75±0.1	3.5±0.05	4±0.1	2±0.05	2±0.05	1.5 ^{+0.1/-0}	0.45±0.1
RS-03	1.1±0.1	1.9±0.1	8±0.2	1.75±0.1	3.5±0.05	4±0.1	4±0.05	2±0.05	1.5 ^{+0.1/-0}	0.7±0.1
RS-06	1.9±0.1	3.5±0.2	8±0.2	1.75±0.1	3.5±0.05	4±0.1	4±0.05	2±0.05	1.5 ^{+0.1/-0}	0.85±0.1
RS-10	2.9±0.1	3.5±0.2	8±0.2	1.75±0.1	3.5±0.05	4±0.1	4±0.05	2±0.05	1.5 ^{+0.1/-0}	0.85±0.1

EMBOSSED PLASTIC TAPE SPECIFICATIONS

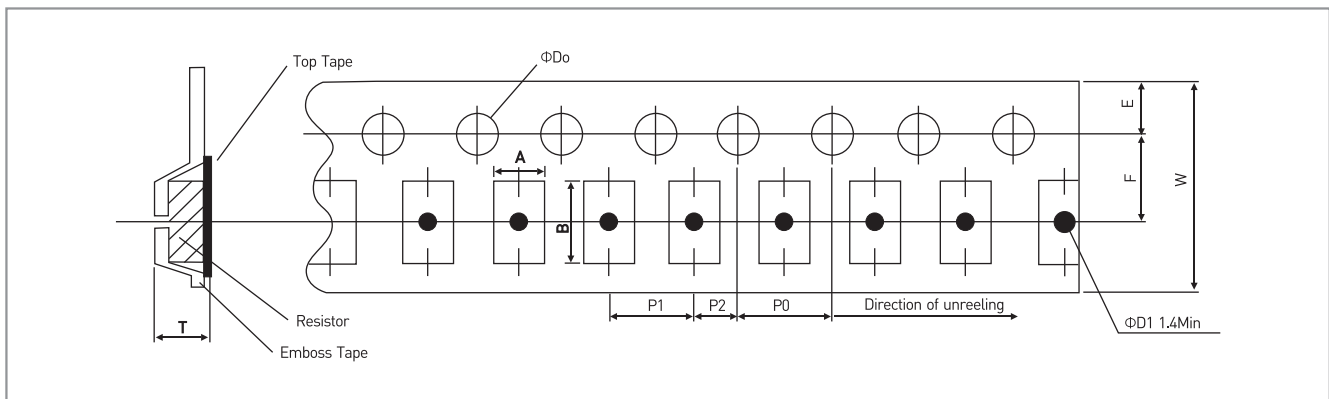

Model	A	B	W	E	F	P ₀	P ₁	P ₂	ΦD ₀	T
RS-0A	2.8±0.10	5.5±0.10	12.0±0.30	1.75±0.10	5.5±0.05	4.0±0.10	4.0±0.10	2.0±0.05	1.5 ^{+1/-0}	1.2±0
RS-12	3.5±0.10	6.7±0.10	12.0±0.30	1.75±0.10	5.5±0.05	4.0±0.10	4.0±0.10	2.0±0.05	1.5 ^{+1/-0}	1.2±0

ORDERING PROCEDURE EXAMPLE

Ordering Example	Model	Power Rating	Resistance	Tolerance	Code
RS-02 L0R05F4	RS-02	L(Standard)	50mΩ	F[±1%]	4(7" Reel 4Kpcs)
RS-03 P0R1J6	RS-03	P(High Power)	100mΩ	J[±5%]	6(7" Reel 10Kpcs)
RS-05 L0R02F7	RS-05	L(Standard)	20mΩ	F[±1%]	7(7" Reel 5Kpcs)
RS-06 P0R5J9	RS-06	P(High Power)	500mΩ	J[±5%]	9(10" Reel 8Kpcs)
RS-10 L0R01FA	RS-10	L(Standard)	10mΩ	F[±1%]	A(10" Reel 10Kpcs)
RS-0A P0R05JC	RS-0A	P(High Power)	50mΩ	J[±5%]	C(13" Reel 40Kpcs)
RS-12 L0R5FF	RS-12	L(Standard)	500mΩ	F[±1%]	F(Bulk)